

Operating Manual

V3 2025.08

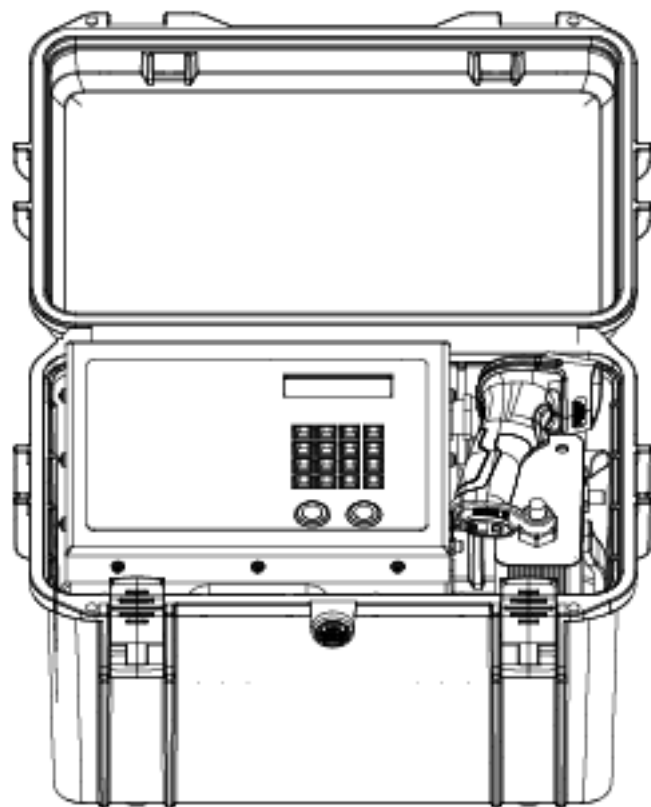

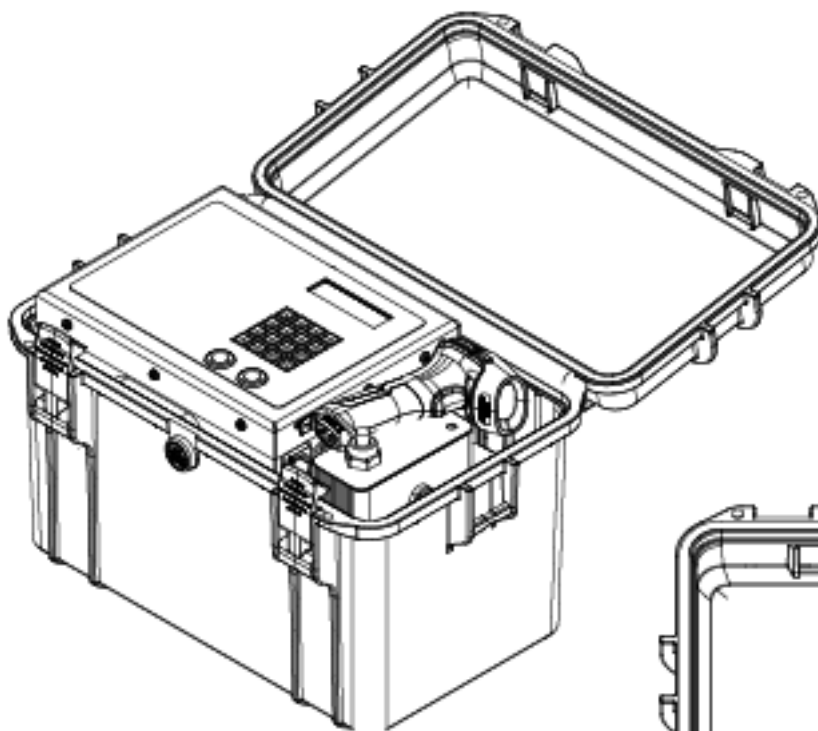

This document is copyrighted by Advance Welding with all right reserved. Unless otherwise authorised by Advance Welding, you are not eligible to use or allow others to use the document or any part of the document by reproducing, transferring or selling the document. Users should only refer to this document and the content thereof as instructions to operate Advance Welding products. The document should not be used for other purposes.



Searching for Keywords

Search for keywords such as "Battery" or Specification" to find a topic. If you are using Adobe Acrobat Reader to read this document, press Ctrl+F on Windows or Command+F



Navigating to a Topic

View a complete list of topics in the table of contents. Click on a topic to navigate to that section.

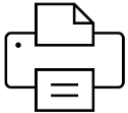

Printing this Document

This document supports high-resolution printing.

Legend



Important



Hints and Tips

Read Before Use

Advance Welding provides users with tutorial videos and the following documents. Before using the product for the first time, it is recommended to follow these steps:

1. **Watch All Tutorial Videos:**
 - Ensure you watch all the tutorial videos provided. These videos will offer visual and practical guidance on how to use the product correctly and efficiently.
2. **Read the Safety Guidelines:**
 - Carefully read the safety guidelines. These guidelines are crucial for understanding how to use the product safely and avoid any potential hazards.
3. **Review the Quick Start Guide:**
 - Before you begin, review the quick start guide. This guide will provide you with the essential steps to set up and start using the product quickly and effectively.
4. **Refer to the User Manual for More Information:**
 - For detailed instructions and additional information, refer to the user manual. The manual will offer comprehensive guidance on all aspects of using the product, troubleshooting tips, and maintenance advice.

By following these recommendations, you will ensure a safe and efficient first-time use of the product.

Index

Introduction	5
Product Profile	5
Delivered Items.....	5
Intended Use.....	6

Product Specification.....	6
Safety Precautions	7
Using the Equipment – Screen Symbols.....	10
Using the Equipment – On / Off.....	11
Using the Equipment – Barcode Welding	12
Using the Equipment – Manual Welding	14
Using the Equipment – Checking Battery Capacity.....	16
Using the Equipment – Downloading Data Log.....	17
Using the Equipment – View Logs.....	18
Web Access Data Logging	21
Fault Finding	21
Hardware Reset	23
Maintenance.....	24
Electrical Safety.....	24
Transport of Dangerous Goods	25
Disposal – End of Life.....	26
Calibration and Warranty.....	27
Declaration of Conformity	29
Service and Repair.....	30

Introduction

This manual gives instructions on the correct assembly and safe use of your welding unit. It is important that you read these instructions carefully and keep them for the life of the unit.

This manual does not detail the specific welding procedure for the fittings: scraping, clamping and assembly of joints. For this information, you must contact the manufacturer of the fittings.

Product Profile

Efuze Lite

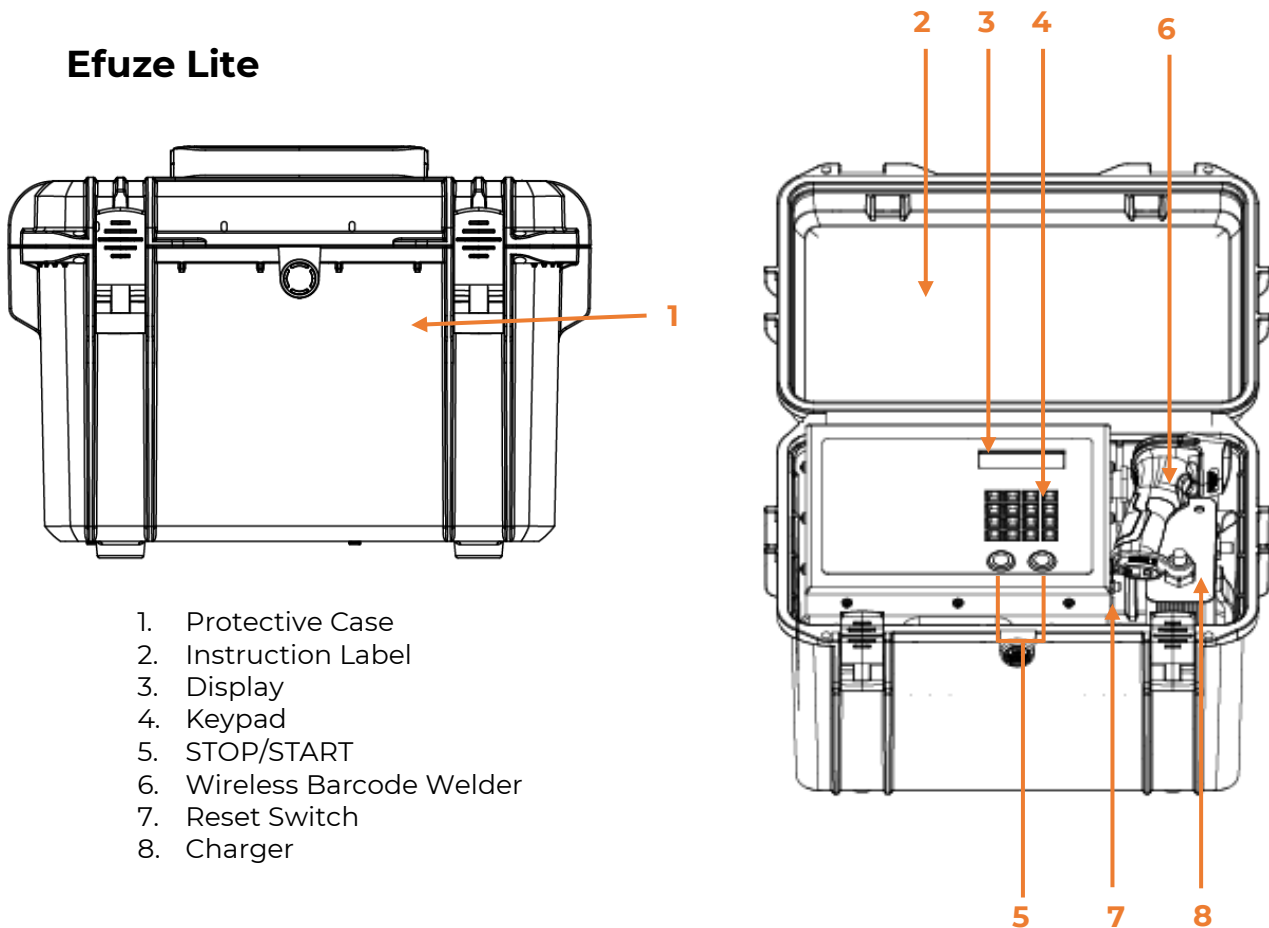

1. Protective Case
2. Instruction Label
3. Display
4. Keypad
5. STOP/START
6. Wireless Barcode Welder
7. Reset Switch
8. Charger

[1] The illustrations in the user manual may differ from the actual product, depending on the country or region. Please refer to the actual product

Delivered Items

Carefully remove the welding unit from its packaging and check that you have the following items:

- Unit
- Wireless barcode scanner
- Mains-powered battery charger.
- +12v DC car charging lead
- USB memory drive
- Operating manual

Intended Use

This equipment is intended to weld constant voltage electrofusion fittings suitable for low, medium and high-pressure pipework systems, up to a maximum diameter of 355mm (14 inches).

This welding unit has been designed to comply with the International Organisation for standardisation standard ISO12176-2:2000 "Plastic pipes and fittings, equipment for fusion jointing polyethylene systems, part 2, electrofusion".

Product Specification

Operating Type:	Controlled Voltage
Operating Modes:	Manual, Bar Code
Operating Languages:	English, French, Spanish, Portuguese (others on request)
Operating Temperature:	-20°C to +45°C #1
Welding Voltage:	8 to 48v (39.5V) (true rms)
Welding Current:	1 to 65 A (true rms)
Welding Power:	8 VA to 2600 VA
Welding Time:	1 to 3000 seconds
Data log memory:	>10,000 welds (Internal memory card)
Data download/upload:	USB flash memory drive
Protection Level:	IP54
Weight:	14 kg
Size:	44 cm x 29 cm x 31 cm
Supply voltage:	Lithium-Ion rechargeable batteries.

Battery charger

Supply voltage:	100V to 240V
Supply Power:	550W (@ 240V)

#1 The batteries can only be charged between 0°C to +45 °c.

[2] Advance Welding has a policy of continuously improving product design and, as such, reserves the right to change the specification of its products without prior notice and with impunity.

Safety Precautions



- RISK OF ELECTRIC SHOCK! Do not open. No user-serviceable parts inside. Only to be opened by an approved service agent.
- RISK OF EXPLOSION! This welding unit is NOT intrinsically safe and must NOT be used in a gaseous atmosphere. Do not use this equipment in the trench.
- Before using, always visually inspect the unit to see that the cables and connectors are not worn or damaged. Replace the damaged part before welding.
- Switch off before adjusting, cleaning, or if the cables are entangled, and before leaving the equipment unattended for any period.
- To avoid damaging the unit, do not disconnect the welding cable while the unit is welding a fitting.
- Do not lift or pull the equipment by its cables.
- Do not disconnect the welding cables by pulling on them; always carefully pull off the connectors from the fitting.
- Do not start a weld without the pipe correctly inserted into the fitting.
- Do not touch the fitting while welding.
- Do not weld in the rain or leave the equipment outdoors while it is raining.
- Weld only in daylight or in good artificial light.
- The operator is responsible for accidents or hazards occurring to other people or their property while using this equipment. Keep the work area safe!
- Keep bystanders a safe distance away from the machine while welding.
- Never allow people unfamiliar with these instructions to use the welding Unit.

Operational Instructions

Equipment Required:

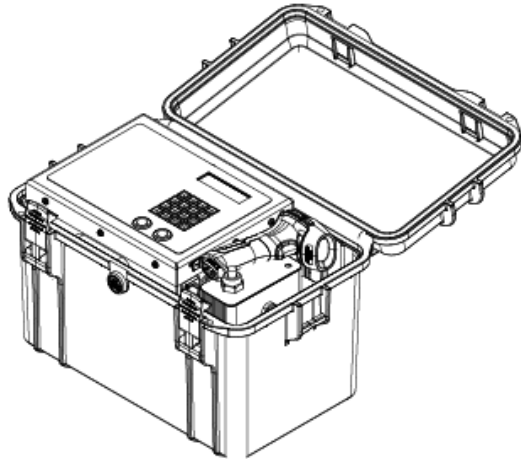

Efuze Lite

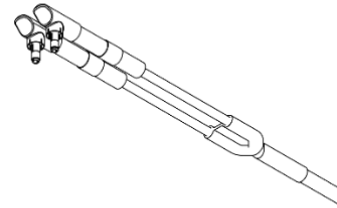

Output cables

1. Connect the terminal ends of the output cable to the joint fitting on the pipe.

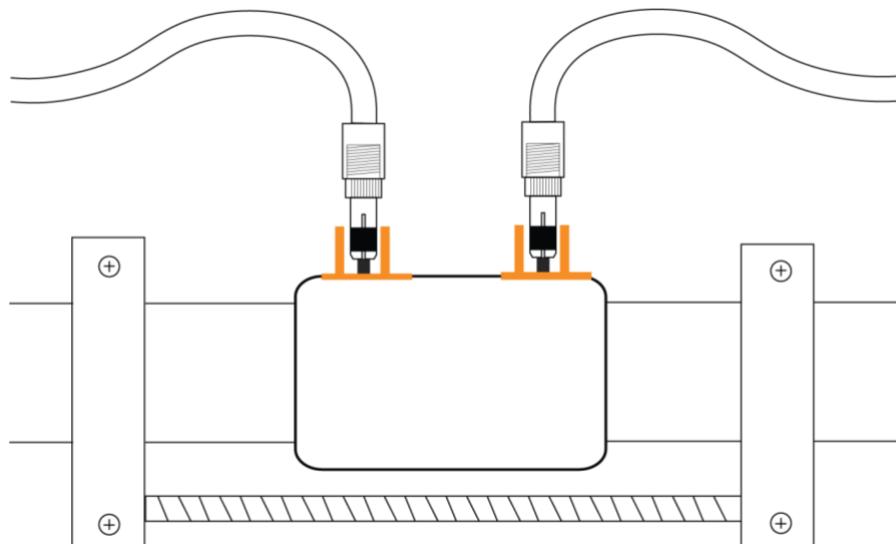

2. Refer to further instructions on the next steps. 'Using the Equipment' pages 14 to 22

Using The Equipment – Screen Symbols

The left-hand side of the screen shows prompts to the operator for the next steps that need to be taken, in this example, connect the welding cable to the fitting or press the star key for the menu.



The right-hand side shows information icons. In this example, the battery is at 98%, the time is 13:00, the GSM radio is disconnected (if fitted) and the Bluetooth is disconnected.

The right-hand side can also show symbols such as pressing the Start button:



In this example buttons A, B or C can be pressed:



Using The Equipment – On / Off

To turn the machine on, press and hold the green START button for three seconds. The display will show:

The product logo.



The manufacturer logo.



The product name.

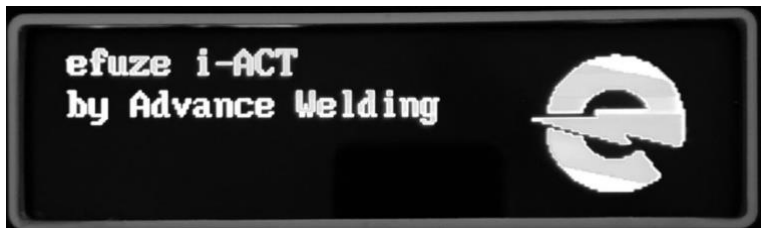

The owner's details.

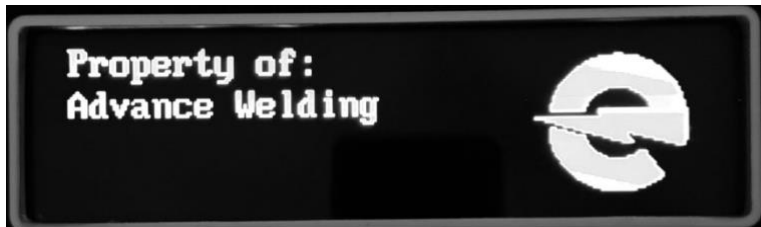

The main screen.



Turning the machine OFF.

To turn the machine on, press and hold the red STOP button for three seconds. The display will turn off.

The machine will auto-power off after five minutes of inactivity.

Using The Equipment – Barcode Welding

Make sure that a barcode scanner/dongle is attached to the USB port.

Connect the welding cable to the fitting.



Scan the barcode on the fitting. If this doesn't read then the numbers can be entered by pressing the A key.

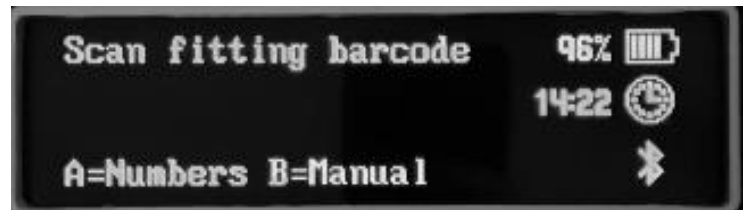

When the barcode is read correctly this screen is shown.

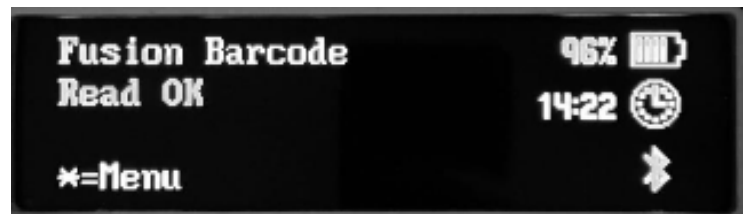

The resistance of the fitting is checked with the barcode to make sure the right code has been scanned.

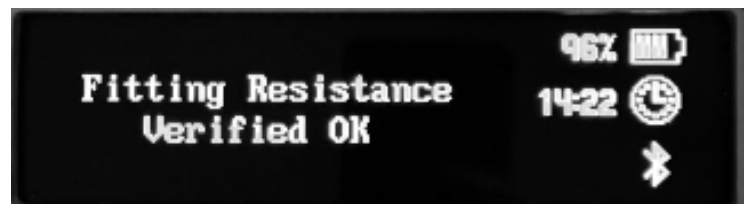

The capacity of the battery is checked and the number of this type of fitting that can be welded is shown.

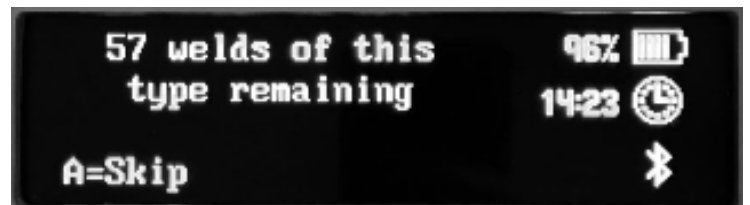

Scan the traceability code on the fitting or press the A key to move on.

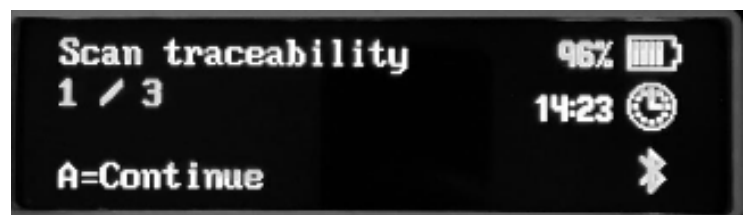

The fitting details are shown. Press the green START button to begin the weld.



A couple of seconds after the start, the calibration is checked. This is the smart-calibration check.

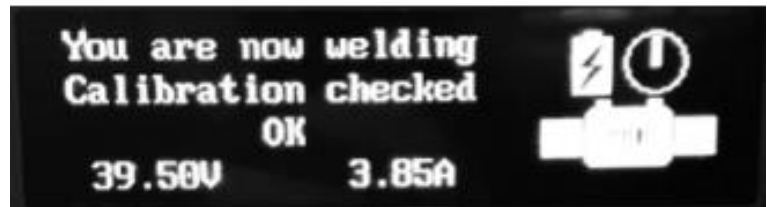

As the weld progresses, the welding voltage and current is shown.



The time counts down to zero and the clock on the graphic fills up to show the weld progress.



When the weld is complete, the cooling time is shown. Allow to complete or press the A key to skip.



At the end of the cooling time, the weld number is shown.

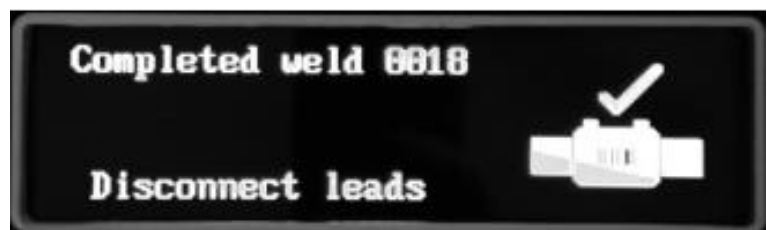

Disconnect the welding leads from the fitting to reset the machine.

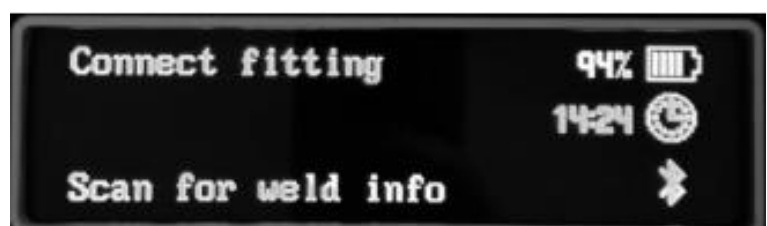

Using The Equipment – Manual Welding

Make sure that a barcode scanner/dongle is NOT attached to the USB port.

Or, during the barcode welding option, press the B the key when the scan fitting the message is shown.

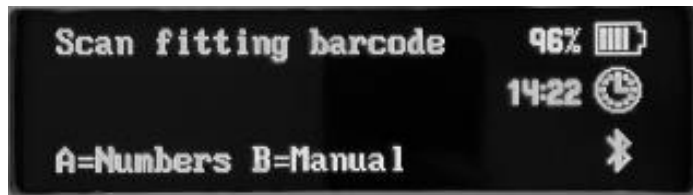

Connect the welding cable to the fitting.

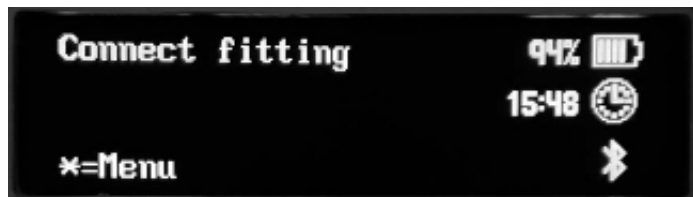

Enter the welding time and press the A key.



Enter the welding voltage. Press the D key to select 39.5 volts.

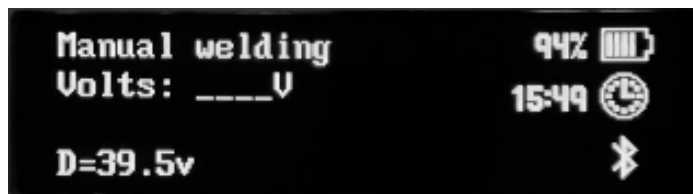

When the voltage is entered, press the A key.

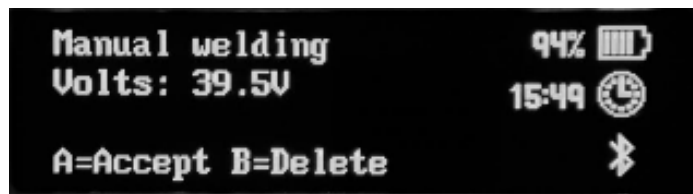

The capacity of the battery is checked and the number of this type of fitting that can be welded is shown.

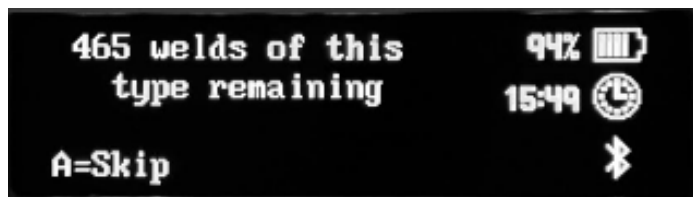

The fitting details are shown. Press the green START button to begin the weld.



A couple of seconds after the start, the calibration is checked. This is the smart-calibration check.

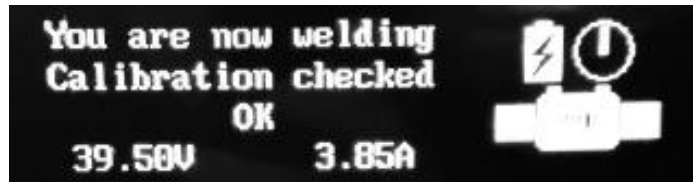

As the weld progresses, the welding voltage and current is shown.

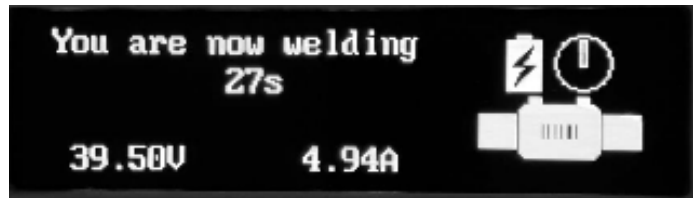

The time counts down to zero and the clock on the graphic fills up to show the weld progress.

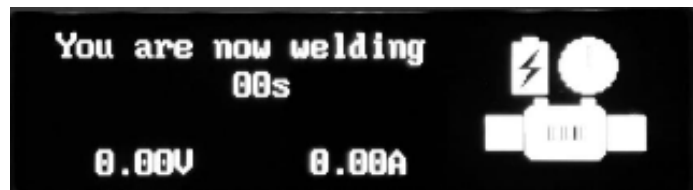

When the weld is complete the cooling time is shown. This will count upwards, press the A key to stop.

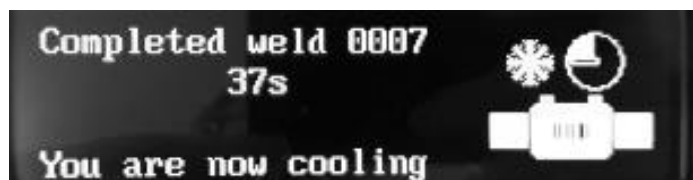

At the end of the cooling time, the weld number is shown.

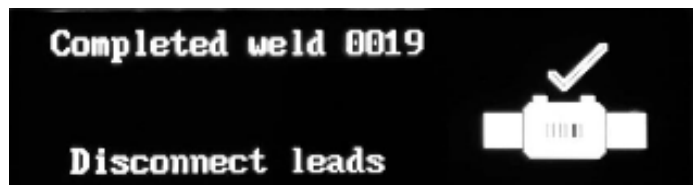

Disconnect the welding leads from the fitting to reset the machine.

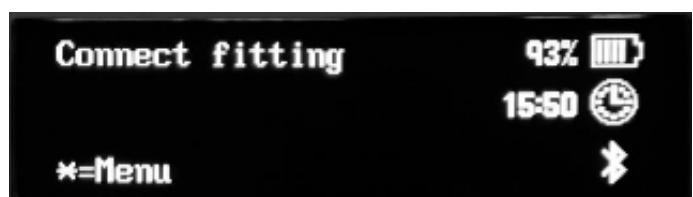

Using The Equipment – Checking Battery Capacity

If you want to know what capacity the battery has and if you can weld specific fitting, this can be done by scanning the fitting barcode and the required energy will be checked from a lookup table held in memory.

When the screen shows connect fitting, with no fitting attached to the welding cable, scan the fitting barcode.

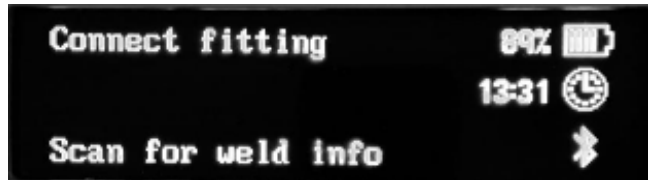

The capacity for this type of the fitting is shown.



Using The Equipment – Main Menu

When the screen shows, press the star key to enter the main menu.



Three options are shown on the screen. Use the B and C keys to select the required option then press A.

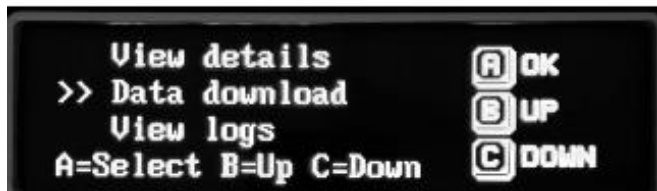

Using The Equipment – Download Data Log

Select data downloaded from the menu.



Select the type of download you want to do. The default is 1: Encrypted.

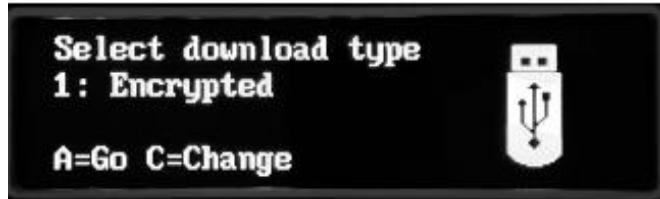

If you want to do an unencrypted XML download and press the C key to change.

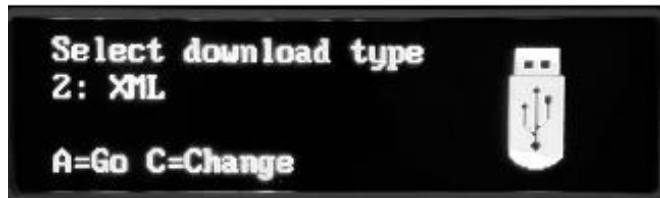

Insert a USB memory drive into the USB port on the machine. You may have to remove the barcode dongle first.



The data log will start to download.



The screen will show the progress of the downloads.

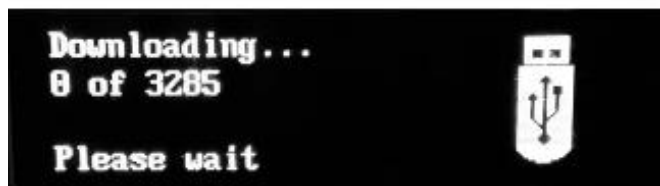

When Success is shown, remove the memory drive from the socket.



Using The Equipment – View Logs

Select view logs from the menu.

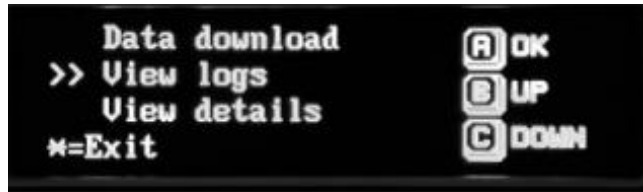

Details of stored welds are shown. Press the A key to view the details.

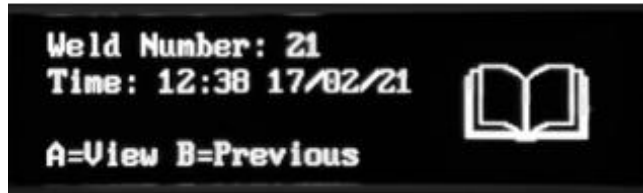

Press the B and C keys to scroll between stored welds.

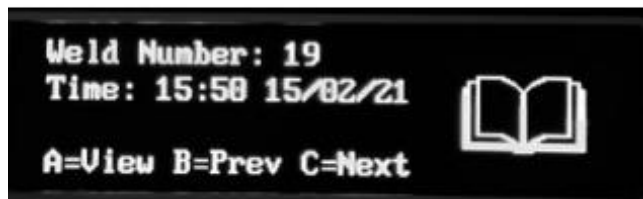

Using The Equipment – View Details

Select view details from the menu.

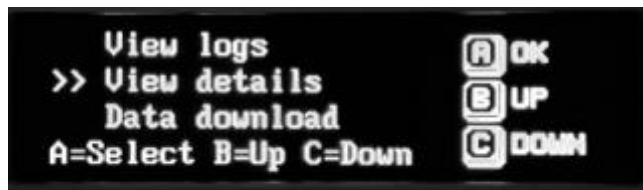

The software version
The number is shown.

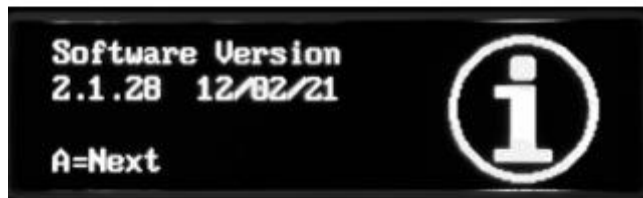

Press the A key to display
the serial number of the
machine.

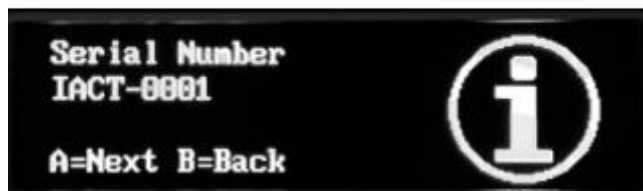

Web Access Data Logging

The Lite is fully compatible with the LOCATE web access data logging system and the Control Point web access quality control system. For more information, please contact your distributor.

Fault Finding

During operation, the welding unit monitors all aspects of its operation. If a fault occurs, then an error message will be shown.

0: Weld OK

No Fault, weld completed OK.

1: Stuck button on start-up

This fault shows when the power is first switched on. Either the Stop, Start, or a keypad button is stuck in. Free the button to clear the fault.

2: Output fault before weld start

This fault shows when the power is first switched on. The unit will check the output terminals to make sure no voltage is present when first switched on. If this fault happens then the internal power relays are stuck in the closed position. The unit will need to be returned for service.

4: No calibration

This fault happens when the unit has no calibration. This will normally not show, and if the unit has been calibrated, would be caused by a fault with the internal memory. Return the unit for service.

7: Ambient temperature less than -20oC.

The unit has detected that the ambient temperature is very cold or the sensor has broken. If the temperature is not below -20oC then the unit will need to be returned to a service agent for repair.

8: Ambient temperature more than +45oC.

The unit has detected that the ambient temperature is very hot, or the sensor has broken or a wire has gone open circuit. The unit must be returned to a service agent for repair.

14: Relay failed to latch on weld start

This fault could happen when the start button is pressed. If the main power relays do not operate correctly then this fault will be shown. The unit needs to be returned for service.

20: Low output volts (-1.25%)

This fault will happen if the output voltage is 1.25% lower than the set point for more than 3 seconds. The unit needs to be returned for service.

21: High output volts (+1.25%)

This fault will happen if the output voltage is 1.25% higher than the set point for more than 3 seconds. The unit needs to be returned for service.

22: Excess output volts (+6.25%)

This fault will happen if the welding voltage is 6.25% more than the set point for more than 2 seconds. The unit needs to be returned for service.

23: Low output current (<2.5A)

This fault will happen if the welding current is below 2.5 amps for more than 3 seconds. It can be caused by a faulty fitting. Try another fitting. If this doesn't clear the fault, then there is a problem inside the unit, and it must be returned for repair.

24: Shorted turn detected in fitting.

While welding, the unit has detected a sharp increase in welding current. This is normally caused by a short turn happening in the fitting. (An increase of 10%). If this happens, then it is most likely a faulty fitting. This must be replaced. If the fault persists, then it could be a fault within the unit.

25: User stop button pressed

The operator has pressed the stop button.

26: Relay unlatched

During welding, if the main power relay disconnects, then this fault will be shown. It could be caused by the unit being knocked. If the fault persists, then the unit should be returned for repair.

27: Fitting an open circuit

This fault is shown if the output lead disconnects from the fitting while welding. Follow the guidelines from the fitting manufacturer, reconnect the lead and try welding again.

29: High output current.

This fault is shown if the welding current is above a predefined limit for a set time. If the fault persists, then the unit should be returned for repair.

30: Bar Code Mode: No fitting connected

This fault is shown if the output lead is not connected to a fitting when a bar code is read. Connect the fitting.

31: Bar Code Mode: Ohms error

This fault is shown if the connected fitting resistance is different from that coded into the barcode. Try another fitting.

40: Bar Code Invalid: Temperature Compensation.

Digits 22 and 23 of the bar code have been decoded incorrectly.

41: Bar Code Invalid: Resistance Coefficient.

Digit 18 of the bar code has been decoded incorrectly.

42: Bar Code Invalid: Welding Voltage.

Digits 13 and 14 of the bar code have been decoded incorrectly.

43: Bar Code Invalid: Regulation Mode.

Digit 12 of the bar code has been decoded incorrectly.

44: Bar Code Invalid: Fitting Size.

Digits 9, 10 and 11 of the bar code have been decoded incorrectly.

45: Bar Code Invalid: Cooling Time.

Digit 7 of the bar code has been decoded incorrectly.

46: Bar Code Invalid: Fusion Cycle Type.

Digit 5 of the bar code has been decoded incorrectly.

47: Bar Code Invalid: Energy Correction.

Digit 3 of the bar code has been decoded incorrectly.

48: Bar Code Invalid: Component Type.

Digits 1 and 2 of the bar code have been decoded incorrectly.

49: Bar Code Invalid: Check Digit.

Digit 24 of the bar code has been decoded incorrectly.

50: USB Memory: Disc full.

This fault will happen if the USB flash memory pen is full. Delete some files from the device.

52: USB Memory: File not found.

When performing a software upgrade, the required file was not found on the memory drive. Reload the upgrade files onto the memory drive.

66: No USB File System

The USB stick has been detected, but the file system is incorrect. Format the USB stick to FAT32, then try again.

74: SD Card Full

This fault will happen if the SD memory is full. The unit should be returned for service.

75: Bluetooth Comms Errors

This fault will happen if there is no communication between the main processor and the Bluetooth module. The unit should be returned for service.

84: DCDC Inverter Disconnected

The main power board is disconnected from the control board. The unit should be returned for service.

99: DCDC Comms Error

The communication between the power board and control board has broken down. The unit should be returned for service.

101: Converter electronics error – Low battery voltage

The battery voltage in the electronics is too low. The unit should be returned for service.

102: Converter electronics error – High battery voltage

The battery voltage in the electronics is too high. The unit should be returned for service.

103: Converter electronics error – High output voltage

The voltage out of the electronics is too high. The unit should be returned for service.

104: Converter electronics warning – Over current

The current out of the electronics is too high. The unit should be returned for service.

105: Converter electronics warning – Communications

The communications between the converter electronics and the microprocessor control has broken down. The unit should be returned for service.

106: Converter electronics warning – Over temperature A

The temperature of the converter electronics phase A is too high. The unit should be returned for service.

107: Converter electronics warning – Over temperature B

The temperature of the converter electronics phase B is too high. The unit should be returned for service.

108: Converter electronics warning – Over temperature C

The temperature of the converter electronics phase C is too high. The unit should be returned for service.

109: Converter electronics error – Phase Current

The current in the converter electronics is out of specification. The unit should be returned for service.

110: Converter electronics error – Relay open

The main control relay in the converter electronics is an open circuit. The unit should be returned for service.

112: Converter electronics error – Voltage sense open

The voltage sensing relay in the converter electronics is an open circuit. The unit should be returned for service.

113: Converter electronics warning – Peak time exceeded

The converter electronics timing circuit has broken. The unit should be returned for service.

114: Converter electronics warning – Phase current mismatch

The current in the converter electronics is out of phase. The unit should be returned for service.

115: Converter electronics warning – BMS fault

The battery management system has developed a fault. The unit should be returned for service.

127: Power off failure.

If the power is turned off while the unit is welding, this fault will be recorded to

Hardware Reset

the data log.

Because this machine is battery-powered, if things go wrong, it is not possible to do a hardware reset by unplugging it from the mains supply. In case this happens, a reset switch is provided.

RESET SWITCH

If the machine software locks up and it cannot be turned off by pressing any of the buttons, the reset switch can be pressed.

Carefully press the reset switch for one second, and the machine will restart.

Warning: Only press the switch if the machine has locked up. Do not press it while welding.

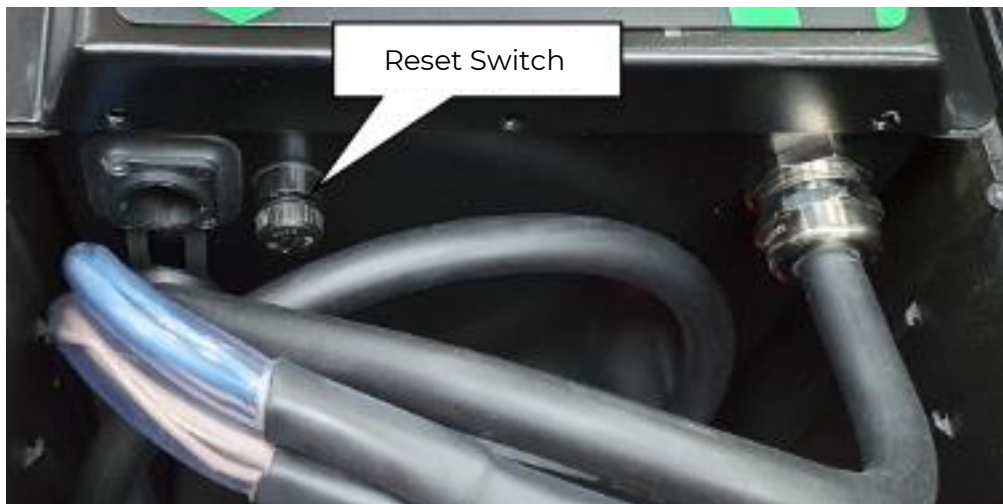

Maintenance

It is very important that the machine case is not damaged, and regularly check for defects such as cracks, broken connectors, or damage that would allow water to enter the machine. If damage is found, then stop using the equipment immediately and contact your distributor for repair.

There are no user-serviceable parts inside the machine. It should be returned to an approved service agent for repair and calibration.

The machine software has a Smart Calibration feature that checks the welding parameters are within specification every time a weld is done. This confirms the output is correct and can extend the service period of the machine to more than twelve months. It is recommended that the machine be serviced every two years.

After use, clean the outside of the machine with a soft brush or cloth. Carefully Wind up and store the welding cable in the location provided.

Electrical Safety

UK law requires equipment to be properly maintained if a lack of (or poor) maintenance would result in danger. As part of this maintenance, inspections are necessary, and testing may be required. There is various relevant legislation, including The Electricity at Work Regulations 1989 and The Electrical Equipment (Safety) Regulations 2016 that detail what inspections are required.

The Flex is a Battery battery-powered inverter so there is no requirement to carry out in-service testing (P.A.T.); however, batteries in equipment can potentially fail and cause fires, so the equipment must be visually inspected for damage to the enclosure to make sure this does not happen.

The operator should carry out a visual inspection on the Flex Battery Powered Inverter every time it is used. If the case is split or broken, or any connectors are damaged, then the equipment must not be used, and it should be returned to your distributor for immediate repair.

The mains-powered charger requires additional testing and is subject to both a visual inspection and an in-service test (P.A.T.).

The operator should carry out a visual inspection on the charger every time it is used.

In accordance with the Electricity at Work Regulations, a risk assessment should be carried out to determine the frequency of in-service testing (P.A.T.), based on how it is being used.

Transport of Dangerous Goods

The Lite welding unit contains a battery pack made from Lithium-ion batteries. These have been classified by the United Nations as hazardous materials and been assigned to Class 9 - Miscellaneous Hazard Classification.

Additionally, the United Nations Committee of Experts on the Transport of Dangerous Goods have classified them under UN 3481 Lithium-ion batteries contained in equipment.

The equipment has passed all relevant tests to allow it to be transported, this information can be viewed at www.advancewelding.co.uk/batteries.

There is a requirement under UN3481 that the product is packaged and labelled correctly for transport. Please save the original packaging in case the machine needs to be transported. It is mandatory that the following labels are attached to the outside of the packaging and the carrier is informed that it contains Lithium-ion batteries.



If you do not have the original packaging, then please visit www.advancewelding.co.uk/batteries for information on how to ship the Efuze machine.

Disposal – End of Life

The equipment and packaging should be sorted for environmentally friendly recycling.

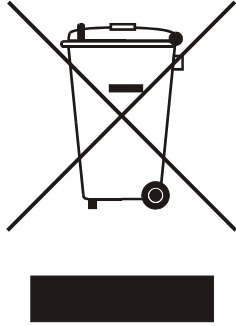

DO NOT DISPOSE OF THIS EQUIPMENT INTO HOUSEHOLD WASTE!

According to the European Directive 2012/19/EU Waste Electrical and Electronic Equipment (WEEE), when no longer suitable for use, this equipment must be separately collected and sent for recycling.



According to the European Directive 2011/65/EU Restriction of Hazardous Substances (RoHS), this equipment does not contain more than the agreed levels of lead, cadmium, mercury, hexavalent chromium, polybrominated biphenyl (PBB) and polybrominated diphenyl ether (PBDE) flame retardants.

www.advancewelding.co.uk/batteries for more information.



According to the European Directive 2006/66/EC Battery Directive, and the UK Waste Batteries and Accumulators Regulations 2009, this product contains Lithium-Ion batteries that must not be disposed of in household waste. Advance Welding will take back-end-of-life batteries. Please visit www.advancewelding.co.uk/batteries for more information.

Calibration and Warranty

IMPORTANT: WARRANTY WILL BE VOIDED IF THE "WARRANTY VOID" STICKERS HAVE BEEN TAMPERED WITH.

This welding unit has been manufactured, inspected and tested in accordance with the quality control systems in place at Advance Welding.

This welding unit has been calibrated using equipment that is traceable to national and international standards through a NAMAS-accredited laboratory. NAMAS (National Accreditation of Measurement and Sampling) is a service of UKAS (United Kingdom Accreditation Service).

This welding unit has a twelve-month warranty period, active from the first use of the unit by the end user customer.

Conditions of Warranty:

This warranty covers only those defects to the product which arise from normal use of the product, and will become invalid if any of the following apply:

- The warranty void stickers have been tampered with.
- Failure to follow the operating instructions.
- Improper or inadequate maintenance.
- Unauthorised modification.
- Misuse or any use not in accordance with the operating manual or good industry practice. Physical abuse of the product.
- Operation outside the product's specifications.
- Improper site preparation or site maintenance.
- Faulty pipe or fitting.

Extent of Warranty:

Subject to the conditions and limitations of warranty, Advance Welding warrants that its electrical products will be free from defects in materials and workmanship for twelve months, and its mechanical products for six months, from the date of purchase by the end-user customer.

If, during this period, notice of a defect which is covered by this warranty is received, then Advance Welding will either repair or replace the product at its option. Any replacement product will have functionality at least equal to that of the product being replaced, and will, in our opinion, perform consistently with its age and usage.

Unless otherwise agreed, all warranty work will be carried out by Advance Welding or an authorised and approved service facility.

Customers will prepay all shipping charges for products returned under warranty, and Advance Welding will charge for the return of the products back to the customer.

Limitations of Warranty:

Advance Welding does not warrant the operation of any product to be uninterrupted or error-free.

Advance Welding specifically disclaims the implied warranties of satisfactory quality and fitness for a particular purpose.

Advance Welding makes no other warranty of any kind, whether expressed or implied, with respect to its products.

To the extent that this warranty statement is inconsistent with the law of the locality where the customer uses the product, this warranty statement shall be deemed modified by the minimum necessary to be consistent with such local law.

To the extent allowed by local law, the remedies provided in this warranty statement are the customer's sole and exclusive remedies.

This equipment has been designed for use with the range of fittings and pipes available at the time of its design and development. Advance Welding can accept NO liability for the equipment's ability or otherwise to be used with new or different fittings or pipe that subsequently appear in the marketplace.

This equipment is not intrinsically safe and must not be used in a gaseous or explosive atmosphere. Advance Welding can accept NO liability if the equipment is used in these circumstances.

Declaration Of Conformity



In compliance with the 'New Approach Standardisation in the Internal Market', the products manufactured by Advance Welding meet the following relevant directives:

2014/30/EU	Electromagnetic compatibility (EMC)
2014/35/EU	Low Voltage (LVD)
2006/42/EC	Machinery (MD)
94/62/EC	Packaging and packaging waste
2011/65/EU	Restriction of the use of certain hazardous substances (RoHS)
2006/66/EC	Battery directive

The products do not fall within a predefined scope, so CE compliance is self-certified.



The United Kingdom Conformity Assessed mark came into force in the UK on 1st January 2021.

Advance Welding is registered with the Environmental Agency as a Manufacturer of Industrial Batteries as per the requirements of the Office for Product Safety and Standards.

Our Battery producer registration number (BPRN) is: **BPRN09029**

More detailed information is available on our website at www.advancewelding.co.uk

On behalf of

Advance Welding:

K. Wilkinson.

Service and Repair

For all service and repair of this machine, please return it to the manufacturer:

Manufactured in the UK by:

ADVANCE WELDING

Units 1 & 2
Taylor Street
Cleckheaton
West Yorkshire
BD19 5DZ
United Kingdom

Tel: 0844 880 7748
Fax: 0870 752 6139

Email: sales@advancewelding.co.uk
Web: www.advancewelding.co.uk

